



**ASTERION RTL
BATTERY SYSTEM MANUAL**

MANUAL EXPLANATION

- COTENT EXPLANATION**

Asterion RTL series back-up lithium iron phosphate battery system is developed for backup of Telecom equipment. Under normal condition, grid AC power supply to rectifier module and the Telecom loads (the load of figure showed below) and charge battery pack; When the AC power fail, rectifier module stop power supply, the battery serves for Telecom equipment, to ensure the Telecom equipment runs normally; This manual contains working principle , structure ,operating parameters and installation of Asterion RTL system

Chapters	Contents
1. Overview	Background, Applications and Advantages
2. Structure and principle	Structure and operating principle
3. Parameters	All parameters of Asterion RTL
4. Installation	Installation and operation
5. Shipping, Storage, and Disposal	Shipping, Storage, Maintenance And Disposal





- BEFORE YOU START**

Read all the safety information provided in this document prior to installing and/or operating the equipment. Contact Asterion Support immediately for a free consultation, if you have any questions about the handling, operation and safe use of the battery.

To handle or operate with Asterion RTL Power System:

- You must be qualified for electrical work;
- Remove any possible metallic shorting risk of Jewel, Watches, Pens. Metal bars and frames;
- All tools must be insulated.

- SAFETY SYMBOLS

Symbol	Definition
	Important safety information will follow.
	DO NOT dispose of battery in a fire.
	Recycle or dispose of Lithium batteries in accordance with local Laws/regulations.
	DO NOT dispose of battery in the trash.

CAUTIONS

What not to do

Please read and comply with the following conditions of installation and use of the battery, incorrect installation using the battery may cause personal injury or damage to the product.

1. **DO NOT** throw the battery into water. Store batteries in a cool and dry environment when not in use.
2. **DO NOT** put the battery into fire or heat the battery, so as to avoid explosion or other dangerous events.
3. When charging the battery, please choose specialized charging equipment, and follow the correct procedures, do not use unqualified chargers.
4. **DO NOT** reverse positive and negative terminals, do not connect the battery directly to AC power, avoid battery short circuit.
5. **DO NOT** use batteries from different manufacturers or different kinds, types together, and do not use old batteries along with new batteries.
6. **DO NOT** use the battery when it becomes hot, bulges, deforms or leaks.
7. **DO NOT** puncture the battery by nail or other sharp objects; Do not throw, stamp on, impact or hit the battery.
8. **DO NOT** open or try to repair the battery when it is defective. Warranty invalid if the battery repaired or disassembled.

Precautions

1. Batteries are half charged before shipment. Don't use the battery if it's hot, bulge, or smell abnormal and so on, and report to Asterion after-sales department immediately.
2. If you need to store the battery for a long time, please charge and discharge the battery every three months to ensure the best performance, and the best state of charge for storage is between 50%~60%.
3. Please use the battery in the temperature range which defined in the manual.
4. The state of charge of batteries is 50% before shipment, please charge the battery before use or test.

CONTENTS

1	OVERVIEW	6
1.1	BACKGROUND AND APPLICATIONS.....	6
1.2	ADVANTAGES.....	6
2	PRINCIPLE AND STRUCTURE	7
2.1	OPERATING PRINCIPLE.....	7
2.2	CONECTING STRUCTURE.....	7
3	PARAMETERS.....	8
3.1	MODELS.....	8
3.2	CONTROL PANEL	9
3.3	BATTERY MANAGEMENT SYSTEM (BMS)	11
3.3.1	VOLTAGE PROTECTION	11
3.3.2	CURRENT PROTECTION.....	12
3.3.3	TEMPERATURE PROTECTION	12
3.3.4	CELL BALANCE.....	13
3.3.5	DISPLAY (OPTIONAL).....	13
4	INSTALLATION AND TESTING	15
4.1	PREPARE TO INSTALL.....	15
4.1.1	REQUIREMENTS OF INSTALLATION ENVIRONMENT	15
4.1.2	TOOLS AND MATERIALS.....	16
4.1.3	SITE SURVEY	16
4.1.4	BATTERY CHECK-UP.....	17
4.2	INSTALLATION.....	17
4.2.1	CAUTIONS.....	17
4.2.2	INSTALLATION STEPS.....	18
5	SHIPPING, STORAGE AND DISPOSAL	19
5.1	SHIPPING AND STORAGE	19
5.2	WARNING AND DISPOSAL	19
5.3	COMMON FAULTS AND SOLUTIONS.....	20

1 OVERVIEW

1.1 BACKGROUND AND APPLICATIONS

Asterion RTL system combines high-energy lithium-iron-phosphate cells and battery management system to achieve the highest level of integrity into intelligent control and monitoring system and can be widely applied into different conditions for telecommunication equipment, mobile comms basic stations etc.

1.2 ADVANTAGES

1. Using the high performance lithium iron phosphate (LiFePO₄) as positive materials, the cycle life is more than 2000 times, floating life up to 10 years, prolongs the service life of backup power supply system.
2. Using the intelligent management system, realize the monitoring and control of battery system under charge, discharge, floating and standby, make sure the system is always in under ideal state of health.
3. Built with comprehensive monitoring system, the battery voltage, current, temperature, volume, state of health is under monitoring. Communicating with PC to realize the real-time monitoring and control through the core CPU.
4. The built-in intelligent balance module, to ensure that the consistency of battery capacity, to extend the service life.
5. Intelligence-design, meet the national standard requirements, remote-measurement, remote-communication, remote-control and remote-adjustment.
6. System with intelligent thermal management devices, which insure the system work in a wide range of temperature, -20 °C~+60 °C¹.
7. With good electromagnetic compatibility and can be matched with standard communication equipment compatibility.
8. Standard and universal sizes.

¹ From -40°C - when using integrated heater option. From -20°C without additional heating.

2 PRINCIPLE AND STRUCTURE

2.1 OPERATING PRINCIPLE

The principle of work of the Asterion RTL series battery system . Under normal condition, grid AC power supply to rectifier module and the Telecom loads (the load of figure showed below) and charge battery pack; When the AC power fail, rectifier module stop power supply, the battery serves for Telecom equipment, to ensure the Telecom equipment runs normally; when the AC power is switched on again, power rectifier module for Telecom equipment recover to while charge the battery pack.

2.2 CONNECTING STRUCTURE

Battery system working principle of Asterion RTL series is shown in Figure 2.1.

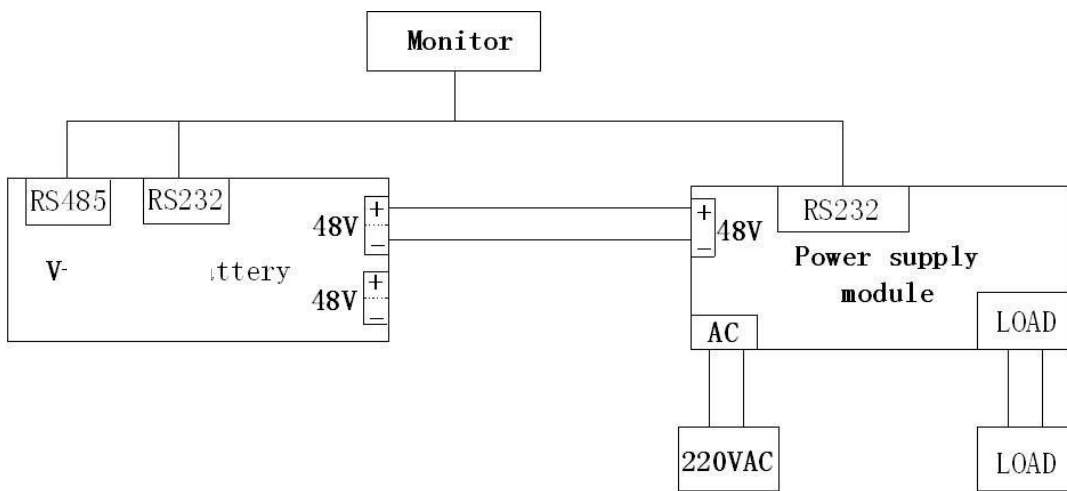

Figure 2.1 Connecting structure of the battery system

3 PARAMETERS

3.1 MODELS

Asterion RTL series products specifications are in Table 3.1

Таблица 3.1 Asterion RTL series products

Model	48V10Ah	48V20Ah	48V40Ah	48V50Ah	48V100Ah	48V150Ah	48V200Ah
Voltage (V)	48	48	48	48	48	48	48
Capacity (Ah)	10	20	40	50	100	150	200
Energy (Wh)	480	960	1920	2400	4800	7200	9600
Length (mm)	442	442	442	442	442	442	442
Width (mm)	285	285	430	440	480	540	640
Height (mm)	44 (1U)	88 (2U)	88 (2U)	134,5 (3U)	134,5 (3U)	190 (5U)	222 (6U)

3.2 CONTROL PANEL

Front panel of an Asterion RTL battery with capacity of 10/20/40/50 Ah, BMS, and components intended for its status indication and monitoring as well as data transmission with other batteries is shown in Fig 3.2a.

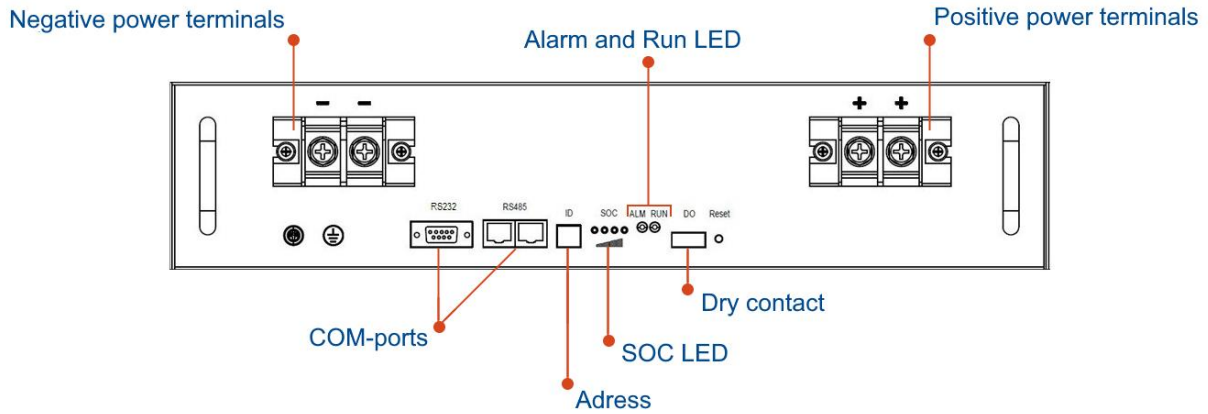

Figure 3.2a Asterion RTL battery with capacity of 10/20/40/50 Ah

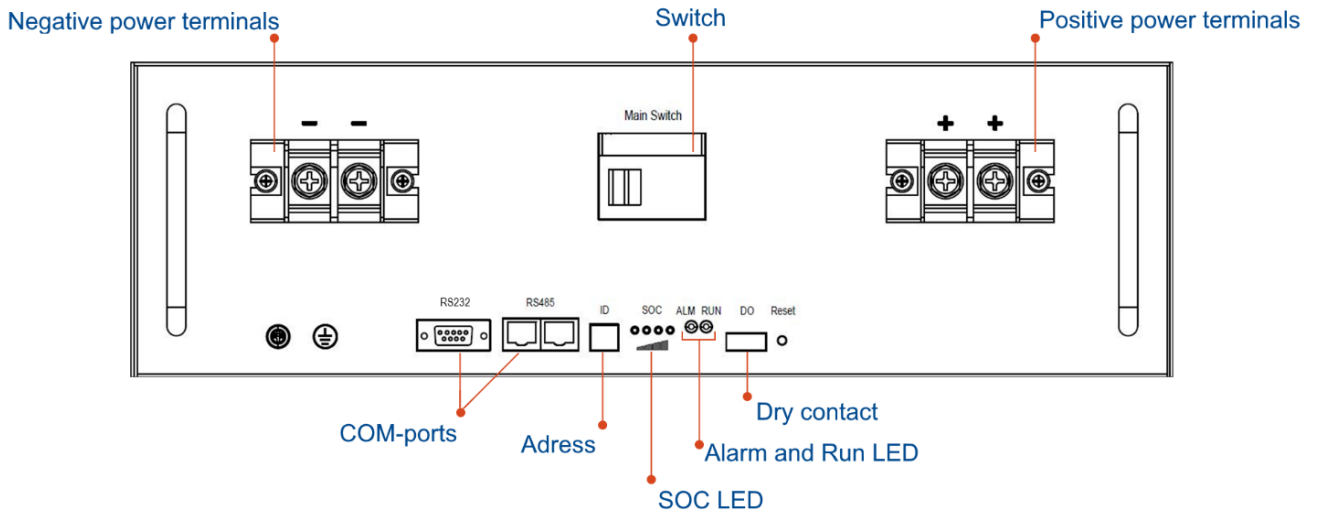

Figure 3.2b Asterion RTL battery with capacity of 100/150/200 A*h

Table 3.3 Interface panel specification

No	Name	Function	Note
1	RS-232, RS-485 ports	Communication interfaces RS-485, RS-232	
2	Address	Assigned to each module connected in parallel	See Table 3.4
3	SOC	State of Charge	Four green LEDs
4	ALM	LED indication of alarm signal	

5	RUN	LED indication of an operating device	Always lights bright when device is operational
6	Dry contact	Special dry contact	
7	Reset	Battery system reset	

Table 3.4 Assignments of ID address

Code				Address	Assign	Note
ON	ON	ON	ON	0	Model	
ON	ON	ON	OFF	1	Model 1	
ON	ON	OFF	ON	2	Model 2	
ON	ON	OFF	OFF	3	Model 3	
ON	OFF	ON	ON	4	Model 4	
ON	OFF	ON	OFF	5	Model 5	
ON	OFF	OFF	ON	6	Model 6	
ON	OFF	OFF	OFF	7	Model 7	

Note: In the table 3.4, bits of code correspond with battery module’s ID in binary system.

Table 3.5 LED indicator description

Status	Normal/Alarm/Protect	RUN	ALM	SOC LED				Description
		●	●	●	●	●	●	
Off/Sleep		OFF	OFF	OFF	OFF	OFF	OFF	All OFF
Standby	Normal	ON	OFF	According to table 3.6				
	Low capacity alarm	ON	Flash 3	OFF	OFF	OFF	OFF	
Charging	Normal	Flash 1	OFF	According to table 3.6				
	Overcharge protection	ON	ON					
	Temperature protection	OFF	ON					
	Charging overcurrent protection	OFF	ON					
Discharging	Normal	Flash 2	OFF	According to table 3.6				
	Overdischarge protection	OFF	ON					
	Temperature	OFF	ON					

	protection			
	Overcurrent / short circuit during discharge	OFF	ON	
Charging / Discharging	Alarm signal	Flash 3	Flash 3	According to table 3.6

Table 3.6 Capacity indicator description

Status		Charge				Discharge			
Capacity indicator		L1●	L2●	L3●	L4●	L1●	L2●	L3●	L4●
SOC	0%~5%	OFF	OFF	OFF	OFF	OFF	OFF	OFF	OFF
	5%~25%	ON	OFF	OFF	OFF	ON	OFF	OFF	OFF
	25~50%	ON	ON	OFF	OFF	ON	ON	OFF	OFF
	50~75%	ON	ON	ON	OFF	ON	ON	ON	OFF
	75~100%	ON	ON	ON	ON	ON	ON	ON	ON
● Operation indicator		Flash 1				Flash 2			

Table 3.7 LED flash definition

Flash type	On	Off
Flash 1	0,5 s	0,5 s
Flash 2	1,0 s	1,0 s
Flash 3	1,5 s	1,5 s

3.3 BATTERY MANAGEMENT SYSTEM (BMS)

3.3.1 VOLTAGE PROTECTION

- **Over-charge protection and recovery**

During charging, if the voltage of any cell exceeds the setting for cell protection or total voltage of the system is greater than the setting for the system, the BMS stop charging. And when all voltage of each cell and total voltage of the battery drop to the recovering-set values, the protection removes automatically. The voltage settings are shown as No. 1,

2 in table 3.8.

- **Over-discharge protection and recovery**

During discharge, if the voltage of any one cell or total voltage of the battery is lower than the protection settings, the BMS stops discharge. And when all cell voltage and total voltage go up to recovering-setting, the protection remove automatically. The settings are shown as No. 3, 4 in table 3.8.

3.3.2 CURRENT PROTECTION

- **Charging over-current protection and recovery**

When the charging current bigger than the charging over-current protection current value and more than the delay time of charging over-current protection, the system would enter the mode of charging over-current protection and turn off the charging MOS. The system would recover from the protection of the charging over-current in every 60 seconds. The settings are shown as No. 6, 7 in table 3.8.

- **Charging current limit**

During charging, if the charging current is greater than the setting value, the BMS will limit the charging current to less than the setting value.

- **Discharging over-current protection and recovery**

When the discharging current beyond the charging over-current protection current and more than the delay time of discharging over-current protection, the system would enter the mode of discharging over-current protection and turn off the discharging MOS. The system would recover from the protection of the discharging over-current in every 60 seconds. The settings are shown as No. 9, 10 in table 3.8.

- **Short circuit protection and recovery**

When the discharging current beyond the value of short circuit protection and reaches the delay time of the short circuit protection, the system would enter the mode of short circuit protection and turn off the discharge MOS. The system wouldn't recover by itself unless remove the load or charge the battery. The settings are shown as No. 11 in table 3.8.

- **Reverse polarity protection and recovery**

When the battery and rectifier are in reserve connection and reaches the delay time of the reverse polarity protection, the system would enter the mode of reverse polarity protection and turn off the discharge MOS. The system wouldn't recover by itself unless remove the rectifier or properly connected rectifier.

3.3.3 TEMPERATURE PROTECTION

- **Cell temperature protection**

There are several thermal sensors to monitor the cell temperature, if the temperature of any cell is higher than 70°C or lower than 0°C, the BMS will stop charging, this is charge temp. protection; If the temperature of any cell is higher than 75°C or lower than - 20°C (- 40°C)², BMS will stop the discharge. This is the discharging protection. The settings are shown as No. 12 in table 3.8.

- **PCB overheat Protection**

There is a thermal sensor to monitor the PCB temperature, if the PCB temperature is higher than 95 °C, it will trigger the PCB protection and stop charging or discharge until the temperature drop to normal range. The settings are shown as 14 in table 3.8.

3.3.4 CELL BALANCE

During charging, If all cell voltages are greater than 3.40V and the voltage difference between cells $\Delta U > 40\text{mV}$, BMS will trigger the balancing process, the balance current is designed base on the capacity of battery pack.

$\Delta U = \text{max. Cell voltage} - \text{min. Cell voltage}$

3.3.5 DISPLAY (OPTIONAL)

The display screen is only for display - when the battery is on, it can show the battery information. There are four buttons: Enter, Back, Up, Down.

By pressing the Enter the button, you can check battery cell voltage, Temperature and Parameters Information. Press the Enter button to check the information of the parameter that the cursor is pointing at. To scroll through the parameters press Up and Down buttons.

² When using integrated heater option



Table 3.8 Protection settings

№	Type	Function	Setting value								Note	
			10	20	40	50	100	150	200			
1	Voltage	Charge	Cell voltage protection								3,90 V Protection	Recover at 3.6V
2			Total voltage protection									
3		Discharge	Cell voltage protection								2,0 V Protection	Recover at 3,1V
4			Total voltage protection									
6	Current	Charge	Normal	≤5A	≤10A	≤40	≤50A	≤100A	≤150A	≤200A		
7			Overcurrent	>5A	>10A	>40	>50A	>100A	>150A	>200A		
8		Discharge	Normal	≤10A	≤20A	≤40A	≤50A	≤100A	≤150	≤200		
9			Overcurrent 1	15~30	15~30	50~60	60~80	105~129	160~180	210~230	Delay 30 s	
10			Overcurrent 2	>30	>30	>60	>80	>129	>180	>230	Delay 3 s	
11			Short circuit	≥200 A				≥300 A				Delay 1 ms
12	Temperature	Cell	Range								Charging range -10°C~70°C Discharging range -20°C~75°C	Delay 1-3 ms
13		Environment	Range									
14		PCB	Range									

Note: When you choose the model of battery, please choose one which has enough discharging current to meet your load requirement.

4 INSTALLATION AND TESTING

4.1 PREPARE TO INSTALL

- **Safety rules**

The installation, operation and maintenance of V-LFP48 series lithium iron phosphate battery system must be performed by trained and qualified professional personnel. Before installation and use, please carefully read the product safety precautions and related operating rules. Strictly abide by the following safety rules and local safety regulations, otherwise may cause personal injury or damage to the product.

1. Make sure that the Telecom equipment to be connected with the battery system is in good condition and free from defects;
2. Before installation, make sure that the power supply system is under shut down state, while the battery system is also under shut down state;
3. All the electricity cables must have corresponding grade of insulation, Please ensure that no exposed cables;
4. Make sure that the battery and power system are reliable grounding.

4.1.1 ENVIRONMENT REQUIREMENTS

Environment requirements are given in the Table 4.2.

Table 4.2 Requirements towards the environment of installation

Requirement	Value
Operating temperature	Operating range: -20°C (-40°C) ³ ~ +60°C
Storage temperature	-20 °C ~ +60 °C
Relative humidity	<95%
Atmospheric pressure	86 kPa~106 kPa

³ When using integrated heater option

Site of installation requirements	No current-conducting dust and corrosive gases, no vibrations. Keep away from heat and flame.
-----------------------------------	---

4.1.2 TOOLS AND MATERIALS

Tools and sources of information to be used are given in the Table 4.3.

Table 4.3 Tools and materials

Name	Name
User manual	Oblique mouth clamp
Screw driver	Multimeter
Wrench	Electrostatic prevention bracelet
Pincers	Insulating tape
Wire stripping pliers	Clamp band

4.1.3 SITE SURVEY

- **Equipment Inspection**
 1. Check that the equipments connected with batteries are right and in good conditions.
 2. Check the DC interface position of the equipment. Check and confirm the output voltage is in the range showed in table 3.7.
 3. Check DC device interface, make sure the maximum output current is matched with the selected battery.
 4. Check the maximal working current of devices backed by the battery , make sure that the current is less than the maximum discharge current of the products showed in table 3.8

- **Ground check**

Check that the battery grounding complies with the local regulations.

4.1.4 BATTERY CHECK

1. On the installation site, check the battery packaging to make sure it's intact;
2. Check battery box according to the packing list, make sure all the material is complete, if any damaged, please fill in the receipt;
3. Please be careful while handling batteries, avoid any damage.

4.2 INSTALLATION

4.2.1 CAUTIONS

When begin to install the battery system, you should pay attention to the following matters:

1. Installation space and load bearing capacity. Make sure that the site's construction meets the requirements of the load bearing capacity.
2. Cable specifications. To ensure that the use of the connection of the power supply line can meet the maximum current requirements of equipment operation.
3. Wiring layout. Ensure that the wiring reasonable, orderly; and consider the moisture-proof, corrosion prevention.
4. The whole installation process should wear anti-static wristband.
5. The installation site should be at least two people to operate.

Warning: Please ensure the installation site is safe and meets the local regulations before installation.

4.2.2 INSTALLATION STEPS

Battery installation steps are shown in table 4.4..

Table 4.4 Installation steps

Step №	Name	Definition
1	Turn off power supply	The system should be powered off, to ensure that there is no electric in installation process
2	Mechanical installation	1. Mounting lugs installation
		2. Battery fixed installation
3	Electrical installation	1. Grounding cable
		2. Power cable installation
		3. Connecting equipment installation
		4. Communication cable installation
4	Electrical commissioning	Power system commissioning

5 SHIPPING, STORAGE AND DISPOSAL

5.1 SHIPPING AND STORAGE

- **Shipping**

According to the provisions of the product can be used in general means of conveyance, but should avoid throwing, rain fall, strong radiation and corrosion erosion. during transportation, please prevent the collision and strong vibration.

- **Storage**

Store device in the indoor storage, the ambient air temperature is 0 °C to + 45°C, the average monthly relative humidity of not more than 90%, the ambient air without corrosive and flammable and explosive gas; storage warehouse should be ventilated, free of alkaline, acidic substances and other corrosive gases, without a strong mechanical vibration, shock, and without strong electromagnetic field and direct sunlight. Capacity was maintained at 50% to 60% stores, and charging the battery every 6 months.

5.2 WARNING AND DISPOSAL

When the ALM lights, battery has been alarmed or protected, please check fault reasons and take corresponding measures. Table 5.1 below is the main alarm condition.

Table 5.1 The main alarm and protection

State	Type	Indicator	Disposal
Charging	Overvoltage protection	ALM	Stop charge, check module voltage and charger
	Overcurrent protection	ALM	Stop charge, check the settings and limitation
	Temperature protection	ALM	Stop charge, wait for the temp recovery
Discharging	Low voltage protection	ALM	Stop discharge, turn to charging mode
	Overcurrent protection	ALM	Stop discharge, check if there is an over load
	Temperature protection	ALM	Stop discharge, wait for the temp recovery

5.3 COMMON FAULTS AND SOLUTIONS

Common faults and solutions are shown in table 5.2.

Table 5.2 Common faults and solutions

№	Fault	Possible cause	Solution
1	LED «RUN» does not light after START	Battery management system is not on	Press the reset button to reset the system, then boot the system again
2	No DC output	Low voltage protection	Charge the battery and try again
3	Power supply time is too short	Battery capacity lack or not full power	Maintenance or replacement
4	Battery can not be charged to full	Power system DC output voltage falls below the minimum charge voltage	Regulating DC output voltage of power supply to battery suitable charging voltage
5	ALM LED always lights	Power line connection short circuit	Disconnect the power cable and check all cables
6	The battery output voltage is unstable	Battery management system does not operate normally	Press the reset button to reset the system, then boot the system again
7.	Communication lost or data gault	Communication settings failure	Check the communication settings and correct it

Note: If you have some special technical problems which not mentioned above, please contact ENERGON technical staff..



ENERGON TÜRKİYE
Phone/fax: + 90 212 951 00 59
E-mail: info@energonturkey.com
asterion-batt.com.tr